



Bullet Style Flush Mount Camera with Parking Lines User Manual



Introduction

Thank you for purchasing your EchoMaster Pro automotive camera.

The following part numbers are supported:

- ▶ **PCAM-220-P**
- ▶ **PCAM-220-N**

EchoMaster Pro cameras are designed to improve safety during driving by providing high quality images of surrounding areas and obstacles in the vicinity of the vehicle. They will also improve vehicle maneuvering capability by displaying blind spots not normally visible to the driver.

Please ensure you read and understand all aspects of this manual before fitting or using your EchoMaster Pro Camera. Choose a suitable mounting place dependent on the application. Ensure that there are no wiring harnesses or hoses/pipes located behind this panel before drilling.

Key Features

- ▶ 1/4" CMOS Sensor
- ▶ Operates at 0.5 LUX
- ▶ IP67 Rated
- ▶ 170 Degree Viewing Angle
- ▶ Selectable Image (mirrored/non-mirrored)
- ▶ Parking Lines (selectable)

Specifications

	PCAM-220-P PCAM-220-N	
Sensor	1/4" CMOS	
LEDs	0	
Illumination	0.5 LUX	
Viewing Angle	170 degrees	
Mirror Image	YES	
Normal Image	YES	
Water/Debris-Proof	IP67	
Audio	NO	
Power Supply	9-16V DC	
Current	<50mA	
Working Temperature	-30°C - +70°C	
Dimensions (mm)	D (22) x W (18) x H (18)	
System	PAL	NTSC
TV Lines	N/A	420
Resolution (HxV)	N/A	648 x 488

Box Contents

- ▶ Camera
- ▶ Manual
- ▶ Mounting Hardware
- ▶ Hole Saw

Dimensions

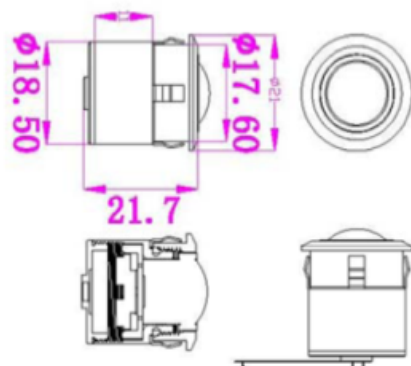

Wiring Diagram

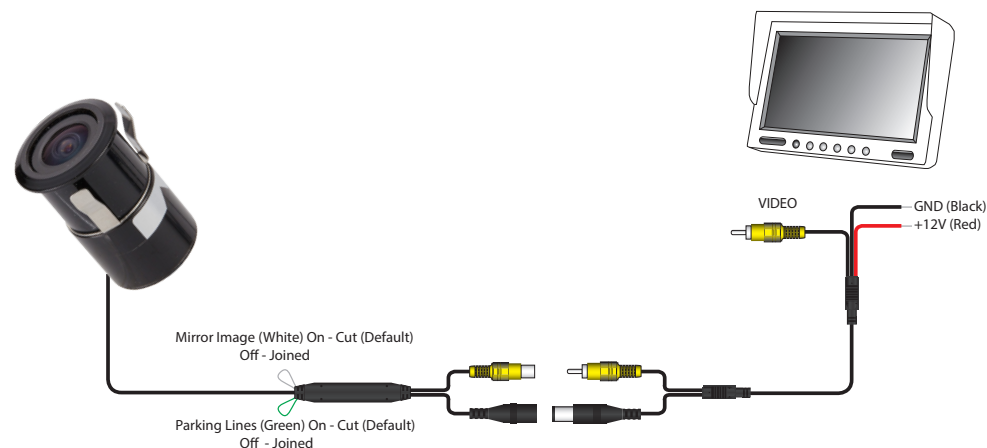

EchoMaster is a Power Brand of AAMP Global
 EchoMaster.com
 15500 Lightwave Drive, Suite 202
 Clearwater, Florida 33760
 email - support@aampglobal.com (US)
 email - technical.eu@aampglobal.com (Europe)

