

EQ9.0

User Manual



**PHOENIX
GOLD**

EQ9.0

featuring: trueTUNE

EQ9.0 USER MANUAL



EQ9.0, 9 band graphic equalizer. Precision tuning for audiophile perfectionists. EQ9.0 gives you 9 bands/frequencies to dial in and tweak your car audio system, delivering your music, your way.

FEATURES:

- Low output impedance
- High input impedance
- Flat frequency response
- High output voltages
- Excellent signal to noise ratio
- Panel mount RCAs
- Poly caps and low tolerance resistors in all signal path circuits
- Removable terminal block for all input connections

SPECIFICATIONS

Maximum Input Voltage	13V
Maximum Output Voltage	9V
THD	0.01%
Input Impedance	20K Ω
Output Impedance	50 Ω
Signal to Noise	>94dB
Band Adjustment	± 10 dB
Crossover Slope (Per Octave)	12dB



EQ9.0 USER MANUAL



1. **Power Connections** for input power, chassis ground, and remote turn-on, use a minimum of 18 gauge copper wire for power and ground connections; power wire should be fused with 1 Amp fuse
2. **RCA Front & Rear Outputs** RCA output jacks provide a fadeable-full range signal to your front and rear amplifiers
3. **RCA Inputs** allow for a normal stereo signal input from various sources
4. **RCA Sub Output** provides a low pass signal to your bass amplifier
5. **AUX Input Gain Adjustment** is used to match the input level with the output level of the source unit connected to the AUX input. When properly adjusted both sources (AUX and Main) should play at the same volume level. The adjustments are individual with one for the left and one for the right channel
6. **Low Pass Frequency (LPF) Adjustment** controls the cutoff frequency of the LPF on the "Sub Out" channels, the crossover filter is switchable from 45Hz to 60Hz.
7. **Subwoofer Level Adjustment** raises and lowers the level of just the "Sub Out" channels to fine tune level based on musical content
8. **Volume Control** raises and lowers the volume on all of the outputs simultaneously
9. **Fader Adjustment** allows you to adjust the level between the Front and Rear channels
10. **Input Selector Switch** selects the Main/Aux
11. **Equalizer Level Adjustment** 9 individual controls at set at fixed frequencies of 50Hz, 125Hz, 250Hz, 500Hz, 1KHz, 2KHz, 4KHz, 8KHz and 16KHz with ± 10 dB of adjustment one each

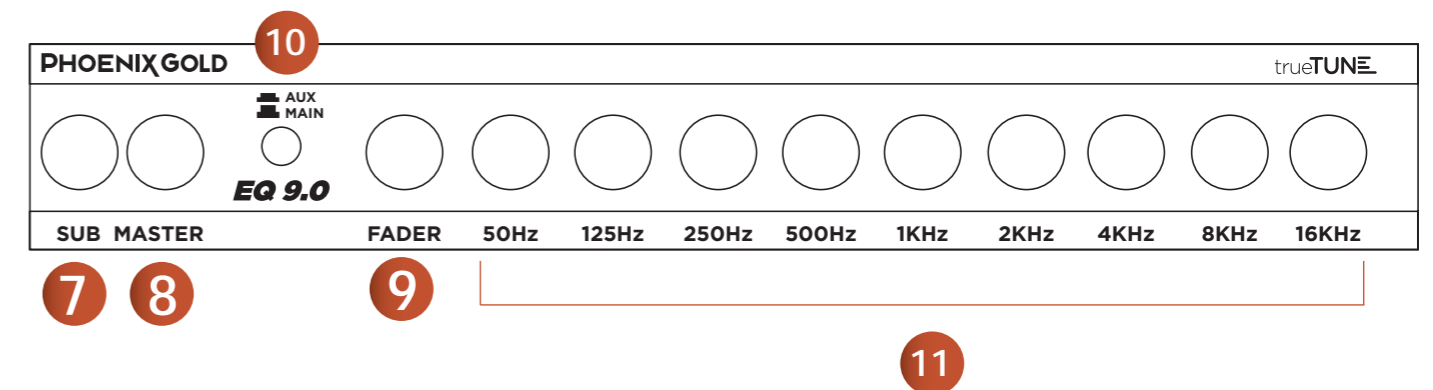
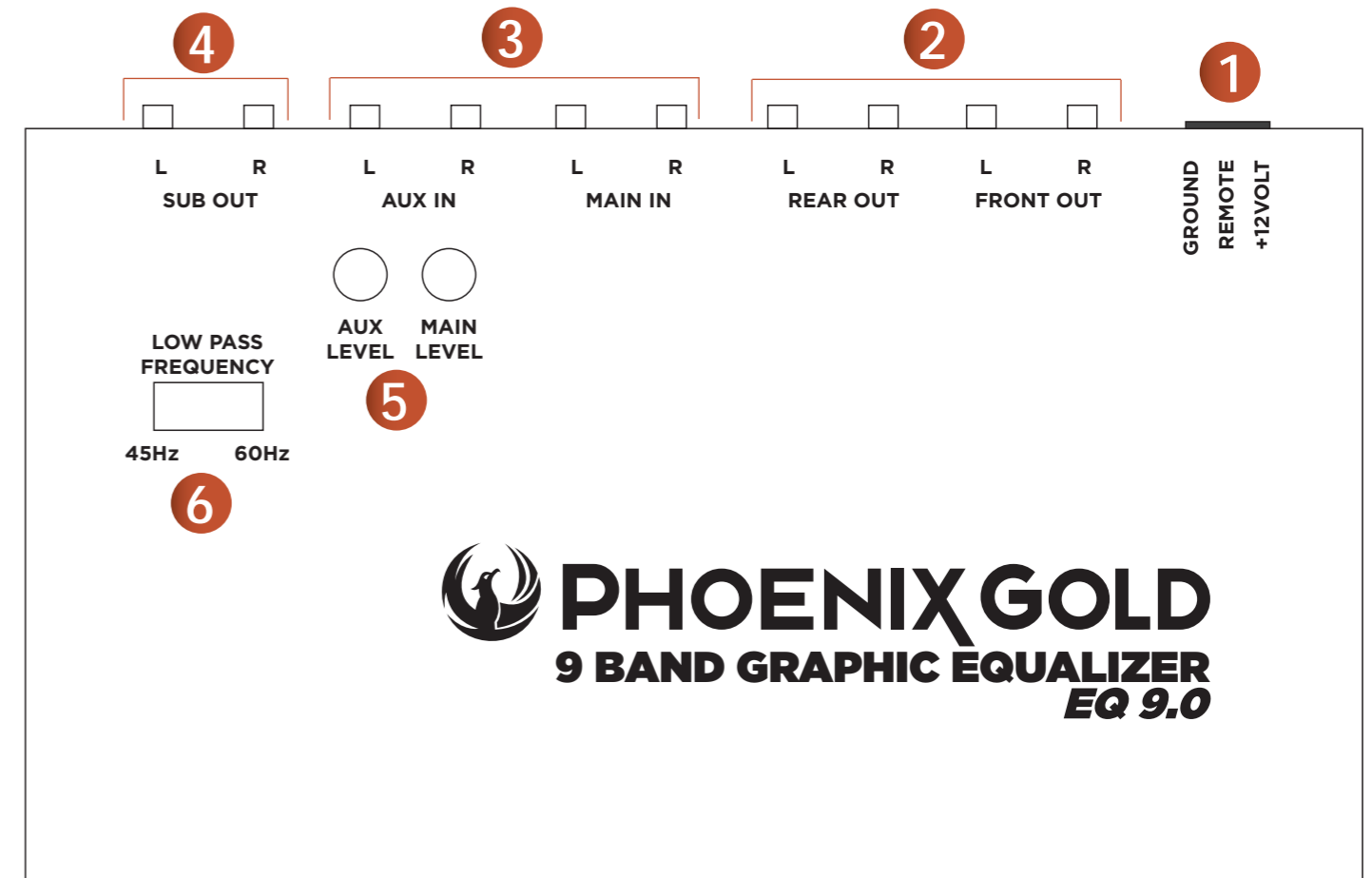

Installation Guidelines

- Always mount the EQ9.0 where it can be easily reached to make adjustments
- Avoid mounting EQ9.0 to a sub enclosure or any other high vibration areas
- Do not cover EQ9.0 with carpet or any other material
- Do not mount EQ9.0 in the engine compartment or anywhere that will subject it to high temperatures (i.e. direct sunlight, or heater), moisture, dust or dirt
- Use rubber or plastic grommets to protect wires when routing them through metal
- Always keep signal wires away from high current power wires
- The ground connection should always be the first connection made

Wiring Instructions

Ground Connection (GND) The main ground connection should be made between the GND terminal on the unit and a metal part of the vehicle close to the mounting location. This wire needs to be as short as possible to minimize the possibility of induced noise. You should use 18ga or larger copper wire for the ground connection. The metal point on the vehicle where the ground connection is made needs to have all paint removed and be scuffed down to the bare metal. The ground wire should have a ring terminal soldered to it and be bolted directly to the vehicle with the use of a star washer. Do not ground the unit near existing (factory) ground points. These areas generally have multiple devices grounded to them and can cause induced noise.

Power Connection (+12V)

The main power connection should be made at the battery. This will ensure that EQ9.0 receives the best possible connection to minimize noise. There must be an inline fuse (1 amp) placed in series with the unit. The fuse should be within 18" of the battery. You should use 18ga or larger copper wire for the power connection. The power wire should have a ring terminal soldered to it and be bolted to the vehicle's battery. Do not install the fuse in the holder until all the system's connections have been made.

Remote In (REM)

The remote in terminal should be connected to the remote lead from the car stereo. This remote lead from the source unit will trigger a +12V output only when the car stereo is turned on. If the source unit does not provide a remote turn-on you can use the accessory terminal in the car's fuse block. This will however turn the unit on and off with the key, regardless of whether the source unit is on or off.

SAMPLE SYSTEMS

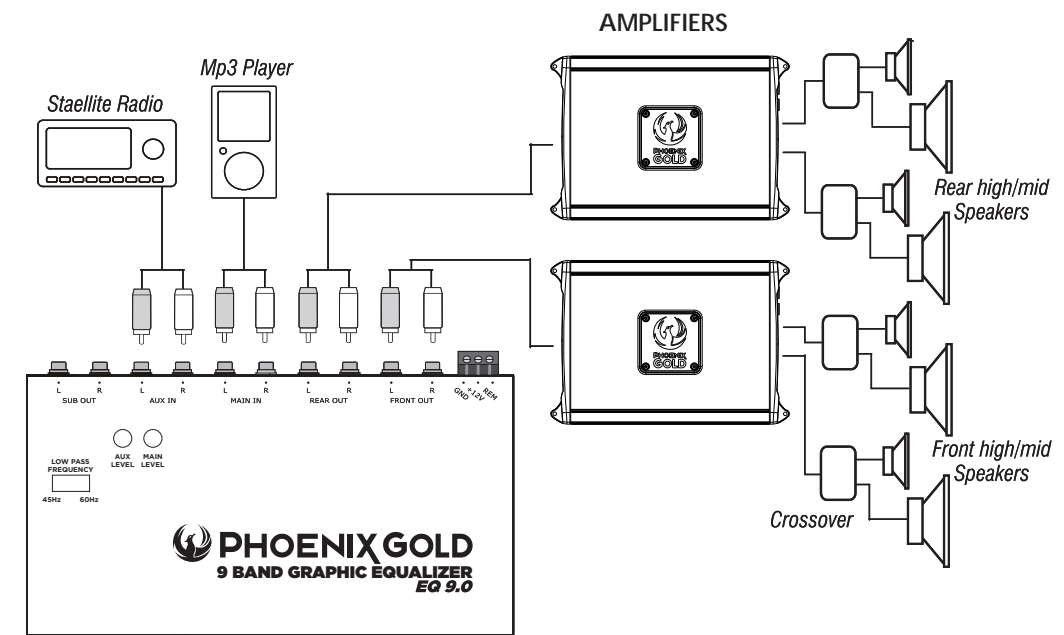
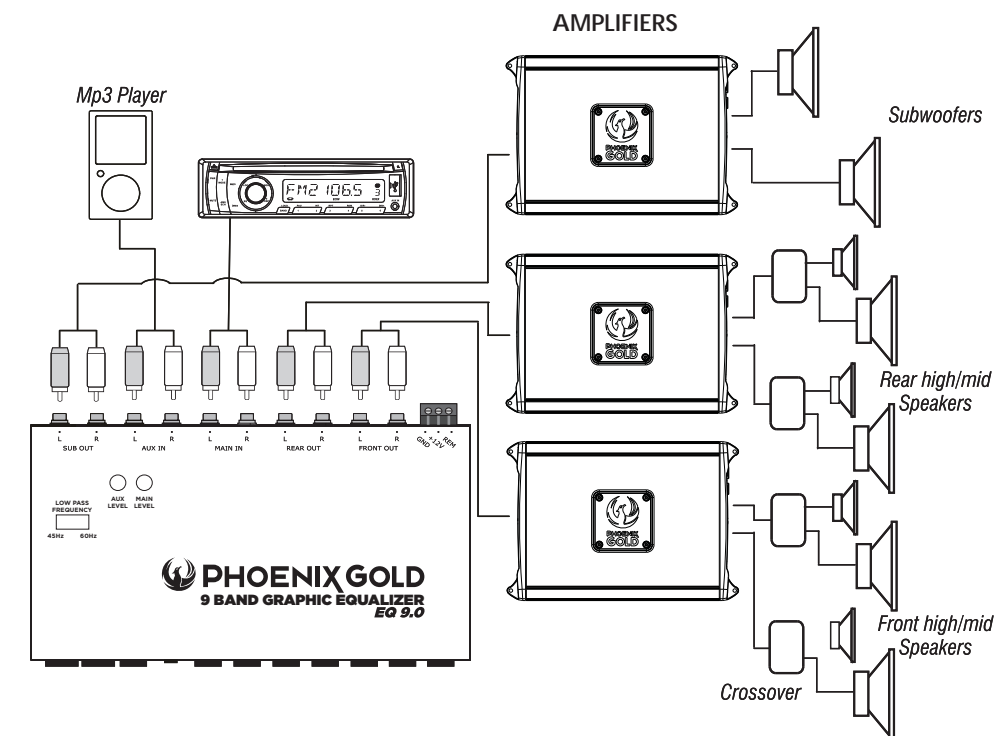
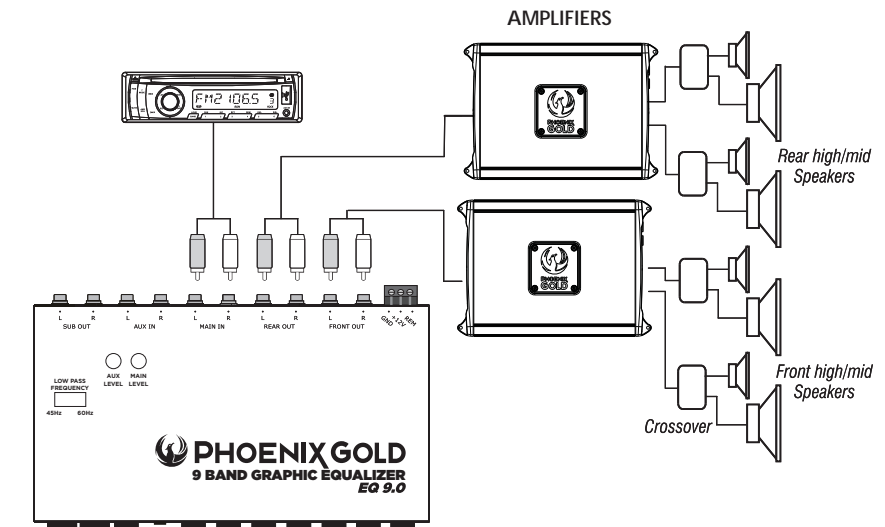



PHOENIX GOLD

Phoenix Gold is a Power Brand of AAMP Global, Clearwater, Florida 33760 - phoenixgold.com - aampglobal.com